

GOVERNORATE: Sharqiya North

2015/2016

ENGLISH LANGUAGE

GRADE FIVE

**Semester One
Second Session**

Name			
School		Class	

Write your answers on the Test Paper

Time: 1½ hours

Pages: 10

TEST SCORES	LISTENING	10	
	GRM/VCB	10	
	READING	10	
	WRITING	10	
	TOTAL	40	

LISTENING 1 (Items 1-5)

[5 marks]

You are going to hear five short texts about people doing different activities. Match the pictures with the texts. For each text, shade in the bubble ● under the correct option.

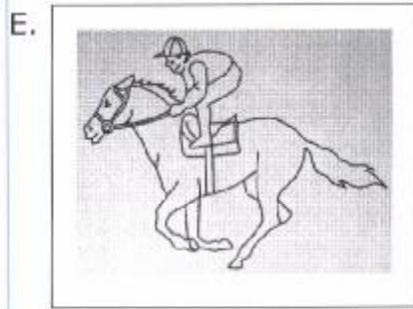
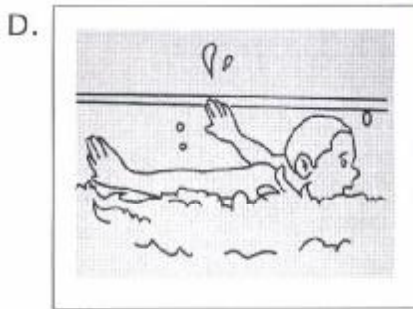
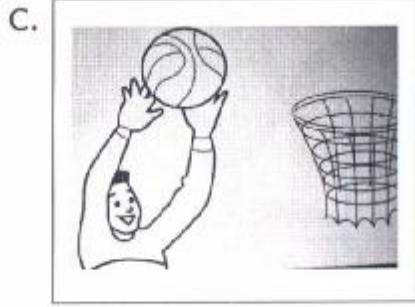
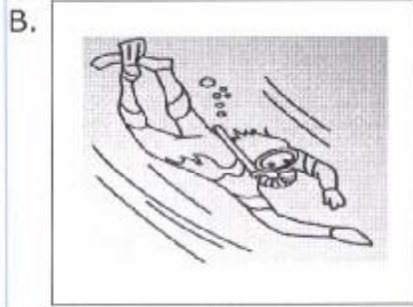
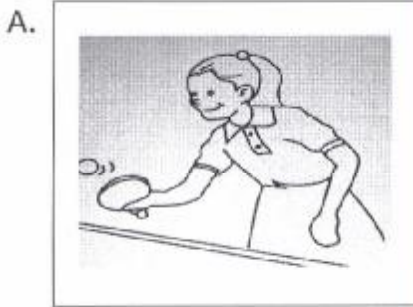

Pictures

Text	A	B	C	D	E	F
1.	<input type="radio"/>	<input type="radio"/>	<input type="radio"/>	<input type="radio"/>	<input type="radio"/>	<input type="radio"/>
2.	<input type="radio"/>	<input type="radio"/>	<input type="radio"/>	<input type="radio"/>	<input type="radio"/>	<input type="radio"/>
3.	<input type="radio"/>	<input type="radio"/>	<input type="radio"/>	<input type="radio"/>	<input type="radio"/>	<input type="radio"/>
4.	<input type="radio"/>	<input type="radio"/>	<input type="radio"/>	<input type="radio"/>	<input type="radio"/>	<input type="radio"/>
5.	<input type="radio"/>	<input type="radio"/>	<input type="radio"/>	<input type="radio"/>	<input type="radio"/>	<input type="radio"/>



LISTENING 2 (Items 6–10)

[5 marks]

You are going to hear someone talking about Fatma.

Listen and number the activities in the correct order (1-5). There is one extra picture.

<p>_____</p>	<p>_____</p>	<p>_____</p>
<p>_____</p>	<p>_____</p>	<p>_____</p>

**LISTENING
SCORE**

10

GRAMMAR/VOCABULARY 1 (Items 1-5)

[2½ marks]

Match the pictures with the words. For each picture, shade in the bubble ● under the correct option.

<p>1.</p> 	<p>2.</p> 	<p>3.</p> 
--	--	--

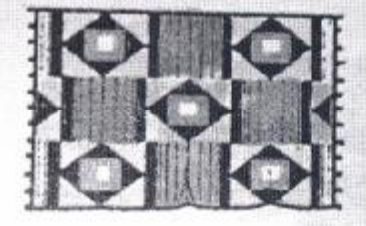
<p>4.</p> 	<p>5.</p> 
---	--

mat	fish	cat	dog	lorry	scarf	rat	car
-----	------	-----	-----	-------	-------	-----	-----

1.	<input type="radio"/>	<input type="radio"/>	<input type="radio"/>	<input type="radio"/>	<input type="radio"/>	<input type="radio"/>	<input type="radio"/>	<input type="radio"/>
2.	<input type="radio"/>	<input type="radio"/>	<input type="radio"/>	<input type="radio"/>	<input type="radio"/>	<input type="radio"/>	<input type="radio"/>	<input type="radio"/>
3.	<input type="radio"/>	<input type="radio"/>	<input type="radio"/>	<input type="radio"/>	<input type="radio"/>	<input type="radio"/>	<input type="radio"/>	<input type="radio"/>
4.	<input type="radio"/>	<input type="radio"/>	<input type="radio"/>	<input type="radio"/>	<input type="radio"/>	<input type="radio"/>	<input type="radio"/>	<input type="radio"/>
5.	<input type="radio"/>	<input type="radio"/>	<input type="radio"/>	<input type="radio"/>	<input type="radio"/>	<input type="radio"/>	<input type="radio"/>	<input type="radio"/>



GRAMMAR/VOCABULARY 2 (Items 6–10)**[2½ marks]**

Complete each sentence with **ONE** word only.

6. How _____ is it? Five rials.
7. I went to Salalah _____ plane.
8. "I am sorry about yesterday. I _____ visiting my uncle."
9. Yesterday, I bought a kilo _____ tomatoes.
10. Muscat is _____ capital city of Oman.



READING 1 (Items 1-5)

[5 marks]

For each picture, shade in the bubble ● next to the correct option.

1.



- The car crashed into a tree.
- The car turned over.
- The car stopped at the traffic lights.

2.



- He is playing basketball.
- They are playing football.
- She is playing tennis.

3.



- He is repairing his car.
- He is cleaning his bike.
- He is riding his bike.

4.

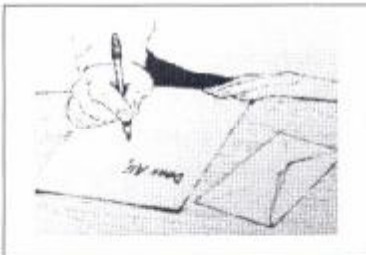

- He is writing a letter.
- She is writing an e-mail.
- He is reading a book.

5.



- It is crossing the road.
- They are sitting by the road.
- They are crossing the road.



READING 2 (Items 6-10)

[5 marks]

Read the text. Are the statements **True** or **False**?

For each item, shade in the bubble ● under the correct option.

Hi everyone,

My name is Salim bin Ali and I am 15 years old. Last week, I and my family went for a meal at one of the big restaurants here in town. It was a very bad time. First, the food came late. We had to wait for a long time to get it. It was also cold. The service was poor. Everybody was very angry about it. The ACs did not work. It was so hot inside the restaurant. We had to leave early. When my father offered me another meal out two days after, I said, "No" "Once is enough."

This is about me. What about you? Please write and tell me.

Best wishes,

Statements	True	False
6. The food was late	<input type="radio"/>	<input type="radio"/>
7. The family ate at home	<input type="radio"/>	<input type="radio"/>
8. Everybody was happy	<input type="radio"/>	<input type="radio"/>
9. The family left early	<input type="radio"/>	<input type="radio"/>
10. Salim went to the same restaurant again	<input type="radio"/>	<input type="radio"/>

READING	
SCORE	10

WRITING 1**[2 marks]**

*Copy these sentences on the lines provided. Make sure your handwriting is **clear** and **easy to read**.*

A. My uncle works for a company in Muscat.

B. Ali has got one sister and two brothers.

C. Salim is my neighbour. He is also my classmate.

Marker A	Marker B	Average

WRITING 2

[3 marks]

Study the pictures. Then complete each sentence.

A.

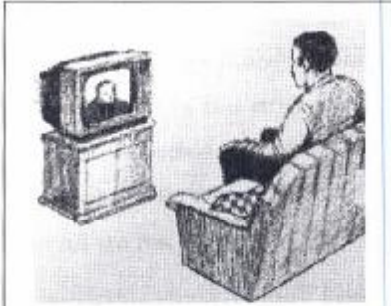

He _____

B.



They _____

C.



She _____

Marker A	Marker B	Average

LISTENING 1 (5 marks)						LISTENING 2 (5 marks)			
	A	B	C	D	E	F			
1.	<input type="radio"/>	<input type="radio"/>	<input type="radio"/>	<input type="radio"/>	<input type="radio"/>	<input checked="" type="radio"/>	2	x	1
2.	<input checked="" type="radio"/>	<input type="radio"/>	<input type="radio"/>	<input type="radio"/>	<input type="radio"/>	<input type="radio"/>			
3.	<input type="radio"/>	<input type="radio"/>	<input type="radio"/>	<input type="radio"/>	<input checked="" type="radio"/>	<input type="radio"/>			
4.	<input type="radio"/>	<input type="radio"/>	<input type="radio"/>	<input checked="" type="radio"/>	<input type="radio"/>	<input type="radio"/>	3	5	4
5.	<input type="radio"/>	<input checked="" type="radio"/>	<input type="radio"/>	<input type="radio"/>	<input type="radio"/>	<input type="radio"/>			

Notes: One mark each. Responses must be indicated clearly.

GRM/ VCB 1 (2.5 marks)								
	mat	fish	cat	dog	lorry	scarf	rat	car
1.	<input type="radio"/>	<input checked="" type="radio"/>	<input type="radio"/>	<input type="radio"/>	<input type="radio"/>	<input type="radio"/>	<input type="radio"/>	<input type="radio"/>
2.	<input type="radio"/>	<input type="radio"/>	<input checked="" type="radio"/>	<input type="radio"/>	<input type="radio"/>	<input type="radio"/>	<input type="radio"/>	<input type="radio"/>
3.	<input type="radio"/>	<input type="radio"/>	<input type="radio"/>	<input type="radio"/>	<input type="radio"/>	<input checked="" type="radio"/>	<input type="radio"/>	<input type="radio"/>
4.	<input type="radio"/>	<input type="radio"/>	<input type="radio"/>	<input type="radio"/>	<input checked="" type="radio"/>	<input type="radio"/>	<input type="radio"/>	<input type="radio"/>
5.	<input checked="" type="radio"/>	<input type="radio"/>	<input type="radio"/>	<input type="radio"/>	<input type="radio"/>	<input type="radio"/>	<input type="radio"/>	<input type="radio"/>

Notes: Half-a-mark each. Responses must be indicated clearly.

GRM/ VCB 2 (2.5 marks)		GRM/ VCB 3 (5 marks)	
6. much		11. what	16. there
7. by		12. an	17. take
8. did		13. Who	18. did
9. of		14. my	19. month
10. the		15. next	20. well

Notes: Half-a-mark each. Spelling must be correct, including grammatical endings.

READING 1 (5 marks)		READING 2 (5 marks)		
1.	<input checked="" type="radio"/> The car crashed into a tree. <input type="radio"/> Xxx xxxx xxxxx xxxxxx xxxx. <input type="radio"/> Xx xxx xxxxxxxx xxx xxxx xxxx.	6.	True <input checked="" type="radio"/>	False <input type="radio"/>
2.	<input type="radio"/> Xxxxxx xxxxx xxx xxxxxx xxx. <input checked="" type="radio"/> They are playing football. <input type="radio"/> Xx xxx xxxxxxxx xxx xxxx xxxx.	7.	<input type="radio"/>	<input checked="" type="radio"/>
3.	<input type="radio"/> Xxxxxx xxxxx xxx xxxxxx xxx. <input type="radio"/> Xxx xxxx xxxxx xxxxxx xxxx. <input checked="" type="radio"/> He is riding his bike.	8.	<input type="radio"/>	<input checked="" type="radio"/>
4.	<input checked="" type="radio"/> He is writing a letter. <input type="radio"/> Xxxxxx xxxxx xxx xxxxxx xxx. <input type="radio"/> Xx xxx xxxxxxxx xxx xxxx xxxx.	9.	<input checked="" type="radio"/>	<input type="radio"/>
5.	<input type="radio"/> Xxxxxx xxxxx xxx xxxxxx xxx. <input type="radio"/> Xxx xxxx xxxxx xxxxxx xxxx. <input checked="" type="radio"/> They are crossing the road.	10.	<input type="radio"/>	<input checked="" type="radio"/>
<p><i>Notes: One mark each. Responses must be indicated clearly.</i></p>				

WRITING 1 (2 marks)		Criteria:
2	Very good.	Consider the overall quality of the hand-writing in the three sentences as a whole : – Are letters <u>easily recognisable</u> ? – Are letters <u>well-formed</u> ? – Are words <u>easily legible</u> ? – Is the <u>size</u> of letters reasonably consistent? – Is <u>spacing</u> between words appropriate?
1.5	Good.	
1	Adequate. (Just good enough)	
0.5	Inadequate. (Not good enough)	
0	No attempt at the task.	
###	#####	
###	#####	

WRITING 2 (3 marks)		Criteria:
3	Very good.	<p>Consider the overall quality of the three sentences as a whole:</p> <p>– Do the sentences <u>make sense</u>? [<i>Is the meaning clear?</i>]</p> <p>– How much <u>relevant information</u> do the sentences communicate? [<i>Are the sentences extremely simple, or does the student try to say a little more about the pictures?</i>]</p> <p>– Is the <u>language</u> in the sentences <u>correct</u>? [<i>Is the grammar/ vocabulary/ spelling/ punctuation(mostly) correct?</i>]</p>
2.5	Good.	
2	Quite good.	
1.5	Adequate. (Just good enough)	
1	Inadequate. (Not good enough)	
0.5	A <u>very</u> weak attempt at the task.	
0	No attempt at the task.	

WRITING 3 (5 marks)	
5	<ul style="list-style-type: none"> – Task achievement is <u>very good</u>. – Meaning is very clear. – Grammar/ Vocab are correct and appropriate. – Spelling and punctuation are very good.
4	<ul style="list-style-type: none"> – Task achievement is <u>good</u>. – Meaning is almost always clear. – Grammar/ Vocab are mostly correct and appropriate. – Spelling and punctuation are good.
3	<ul style="list-style-type: none"> – Task achievement is <u>adequate</u>. – Meaning is clear enough. – Grammar/ Vocab are reasonably correct and appropriate. – Spelling and punctuation are reasonably good.
2	<ul style="list-style-type: none"> – Task achievement is <u>inadequate</u>. – Meaning is sometimes unclear. – Grammar/ Vocab are quite often incorrect or inappropriate. – Spelling and punctuation are often inaccurate.
1	<ul style="list-style-type: none"> – Task achievement is <u>poor</u>. – Meaning is often unclear. – Grammar/ Vocab are very often incorrect and inappropriate. – Spelling and punctuation are very poor.
0	<p><u>No attempt at the task</u>: EITHER Irrelevant (Completely unrelated to the task/ instructions) OR Just copied from the Q-paper OR Hardly any writing at all, or not written in English OR Complete nonsense</p>