

ENGLISH LANGUAGE TEST

GRADE SIX

Semester One

First Session

Name			
School		Class	

Write your answers on the Test Paper

Time: 1½ hours

Pages: 11

TEST SCORES	LISTENING	10	
	GRM/VCB	10	
	READING	10	
	WRITING	10	
	TOTAL	40	

LISTENING 1 (Items 1-5)

[5 marks]

You are going to hear five short texts about people talking about their **jobs**. Match the pictures with the texts. For each text, shade in the bubble under the correct option.

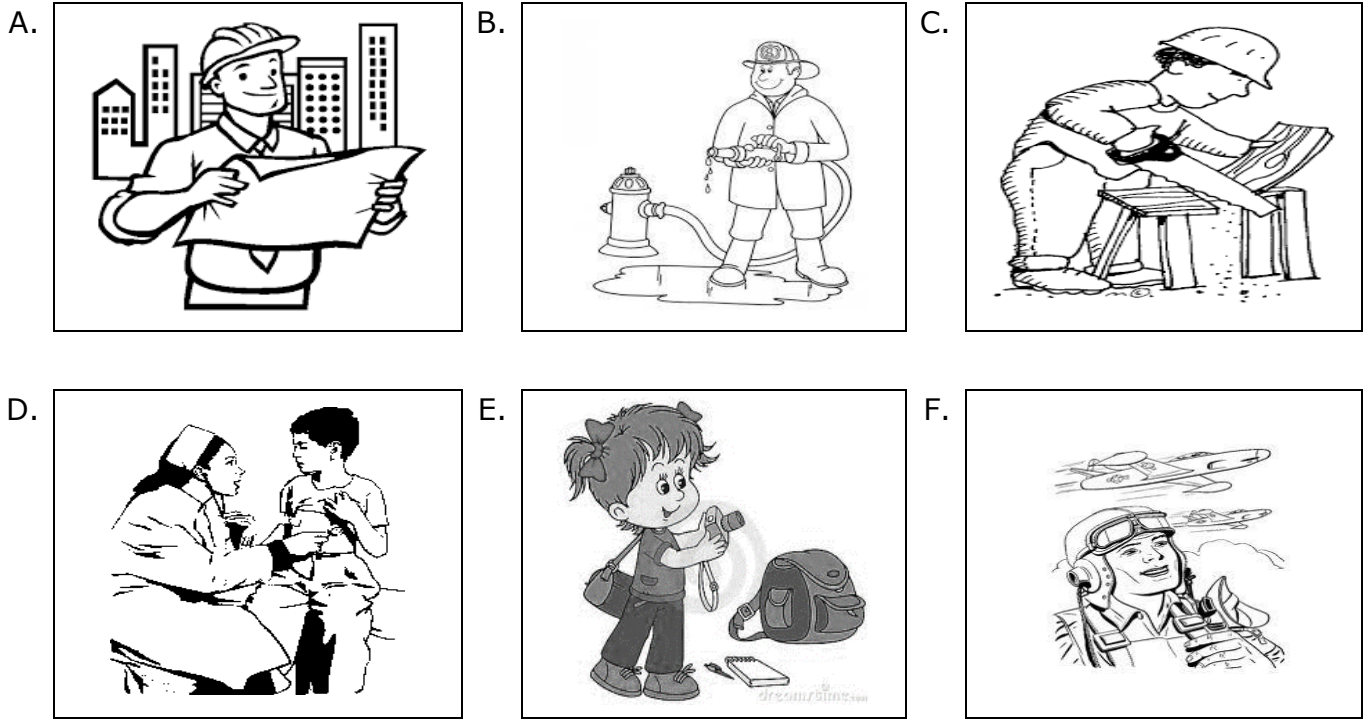

Pictures

Text	A	B	C	D	E	F
1.	<input type="radio"/>	<input type="radio"/>	<input type="radio"/>	<input type="radio"/>	<input type="radio"/>	<input type="radio"/>
2.	<input type="radio"/>	<input type="radio"/>	<input type="radio"/>	<input type="radio"/>	<input type="radio"/>	<input type="radio"/>
3.	<input type="radio"/>	<input type="radio"/>	<input type="radio"/>	<input type="radio"/>	<input type="radio"/>	<input type="radio"/>
4.	<input type="radio"/>	<input type="radio"/>	<input type="radio"/>	<input type="radio"/>	<input type="radio"/>	<input type="radio"/>
5.	<input type="radio"/>	<input type="radio"/>	<input type="radio"/>	<input type="radio"/>	<input type="radio"/>	<input type="radio"/>









LISTENING 2 (Items 6–10)

[5 marks]

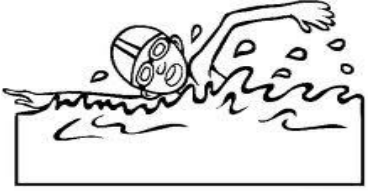
You are going to hear Ali talking about **the sports' club** in his city

Listen and tick (√) if you can play the sport in the club or cross (×) if you can't. The first picture is an example.

		
<p>(e.g.)</p> <p style="text-align: center;">√</p>	<p>(6)</p>	<p>(7)</p>
		
<p>(8)</p>	<p>(9)</p>	<p>(10)</p>

**LISTENING
SCORE**



10

GRAMMAR/VOCABULARY 1 (Items 1-5)

[2½ marks]

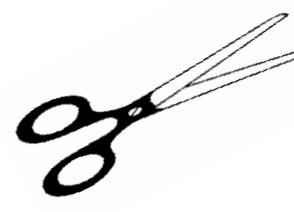
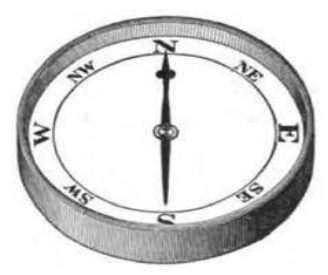
Match the pictures with the words. For each picture, shade in the bubble under the correct option.

1.	2.	3.
		

4.	5.
	

- | | | | | | | | |
|------|--------|------|-------|--------|----------|-----|---------|
| bowl | mirror | hand | torch | ladder | scissors | rug | compass |
|------|--------|------|-------|--------|----------|-----|---------|

1.	<input type="radio"/>	<input type="radio"/>	<input type="radio"/>	<input type="radio"/>	<input type="radio"/>	<input type="radio"/>	<input type="radio"/>	<input type="radio"/>
2.	<input type="radio"/>	<input type="radio"/>	<input type="radio"/>	<input type="radio"/>	<input type="radio"/>	<input type="radio"/>	<input type="radio"/>	<input type="radio"/>
3.	<input type="radio"/>	<input type="radio"/>	<input type="radio"/>	<input type="radio"/>	<input type="radio"/>	<input type="radio"/>	<input type="radio"/>	<input type="radio"/>
4.	<input type="radio"/>	<input type="radio"/>	<input type="radio"/>	<input type="radio"/>	<input type="radio"/>	<input type="radio"/>	<input type="radio"/>	<input type="radio"/>
5.	<input type="radio"/>	<input type="radio"/>	<input type="radio"/>	<input type="radio"/>	<input type="radio"/>	<input type="radio"/>	<input type="radio"/>	<input type="radio"/>



GRAMMAR/VOCABULARY 2 (Items 6–10)**[2½ marks]**

Complete each sentence with **ONE** word only.

6. His name is John. _____ is a teacher.

7. You should play some sports to keep you fit _____ healthy.

8. My father starts work _____ five o'clock.

9. This is my brother's house. _____ is very big.

10. I _____ 12 years old.



GRAMMAR/VOCABULARY 3 (Items 11–20)**[5 marks]**

Complete the unfinished words in the text. Make sure you **spell** each word **correctly**.

EXAMPLE:

"Good morning! My name's Ahmed Al-Zedjali and I'm a student at a school in Muscat. I'm in Grade Six. My favourite subject is Maths."

TEXT

Speaker A: What are **y**_____ (11) wearing?

Speaker B: This is an Omani (12) **khan** _____.

Speaker A: Oh! It's so (13) **ni** _____.

Speaker B: Yes, it's a traditional Omani (14) **cra** _____.

Speaker A: What is it made (15) **o** ____ ?

Speaker B: Generally, (16) **sil** _____, but can be made of gold too.

Speaker A: (17) **Wh** _____ can I find it?

Speaker B: In traditional suqs but there is a (18) **sh**_____ just near my house. I can (19) **ta** _____ you there.

Speaker A: Great! (20) **Th**_____ you very much.

**GRM/VCB
SCORE**

10

READING 1 (Items 1-5)

[5 marks]

For each picture, shade in the bubble next to the correct option.

1.



- He is watching a TV program.
- He is swimming in the sea.
- He is fishing at the river.

2.

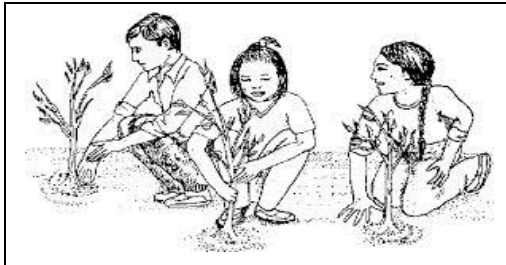

- They are listening to music.
- They are taking some photos.
- They are growing trees.

3.



- The boy is eating popcorn.
- The boy is playing with his sister.
- The boy is writing his math homework.

4.

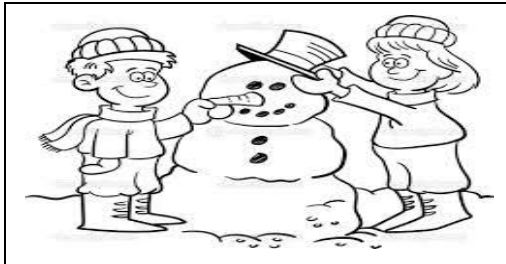

- They are studying in the school.
- They are making an iceman.
- They are climbing a mountain.

5.

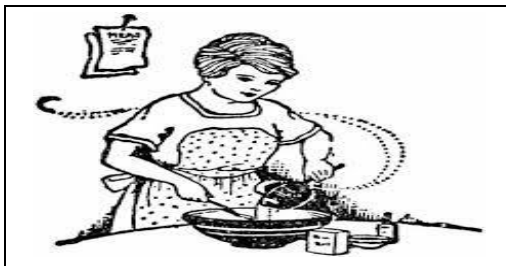

- She is cooking dinner for her family.
- She is reading a book about sport.
- She is writing an e-mail to her sister.



READING 2 (Items 6–15)**[5 marks]**

Read the text. Are the statements **True** or **False**?

For each item, shade in the bubble under the correct option.

Hilal and Sara lived in Dubai. They are married, but they like different things. Last Saturday, They went to Muscat. In the morning they went on a tourist bus. They saw a lot of famous places. They went to an Indian restaurant for lunch. Hilal said that the lunch wasn't good. Sara said it was delicious. In the afternoon, They went to the National Museum of Oman. Sara saw a lot of beautiful paintings. Hilal bought some postcards from the Museum.

Then they went shopping in Muscat Grand Mall. Hilal bought a new CD player and Sara bought some books. The CD player was expensive, but the books were cheap. In the evening, they went to the cinema and watched an action movie. Hilal said that it was boring, but Sara said that it was fun. At the end both of them liked Muscat and they went back home at 11 pm.

READING 2 (cont'd)

Statements	True	False
6. Hilal and Sara like the same things.	<input type="radio"/>	<input type="radio"/>
7. They went to London.	<input type="radio"/>	<input type="radio"/>
8. They had lunch in an Indian restaurant.	<input type="radio"/>	<input type="radio"/>
9. Hilal liked the lunch.	<input type="radio"/>	<input type="radio"/>
10. They went to the National Museum of Oman in the morning.	<input type="radio"/>	<input type="radio"/>
11. They bought some books and a CD player from Grand Mall.	<input type="radio"/>	<input type="radio"/>
12. The books were expensive.	<input type="radio"/>	<input type="radio"/>
13. They watched an action movie.	<input type="radio"/>	<input type="radio"/>
14. Sara enjoyed watching the movie.	<input type="radio"/>	<input type="radio"/>
15. They liked the day in Muscat.	<input type="radio"/>	<input type="radio"/>

READING SCORE
10

WRITING 1**[2 marks]**

Write these two sentences correctly. Put in capital letters and punctuation marks.

A. my best friends are aisha and fatima

B. what are you doing here

Marker A	Marker B	Average

WRITING 2

[3 marks]

Look at the pictures. Then complete each sentence.

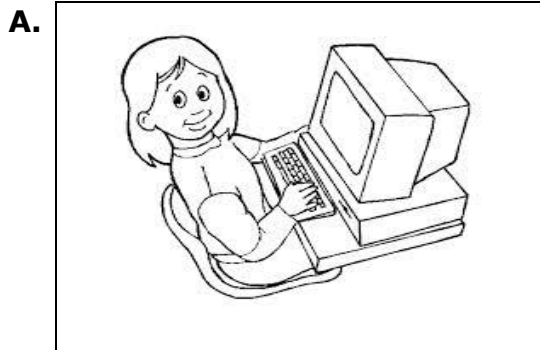

She _____



They _____



He _____

Marker A	Marker B	Average

LISTENING 1 (5 mks)						LISTENING 2 (5 mks)			
	A	B	C	D	E	F		6.	7.
1.	<input type="radio"/>	<input checked="" type="radio"/>	<input type="radio"/>	<input type="radio"/>	<input type="radio"/>	<input type="radio"/>	(e.g.)	<input type="checkbox"/>	<input type="checkbox"/>
2.	<input type="radio"/>	<input type="radio"/>	<input type="radio"/>	<input type="radio"/>	<input checked="" type="radio"/>	<input type="radio"/>		<input checked="" type="checkbox"/>	<input checked="" type="checkbox"/>
3.	<input type="radio"/>	<input type="radio"/>	<input type="radio"/>	<input checked="" type="radio"/>	<input type="radio"/>	<input type="radio"/>	8.	9.	10.
4.	<input checked="" type="radio"/>	<input type="radio"/>	<input type="radio"/>	<input type="radio"/>	<input type="radio"/>	<input type="radio"/>	<input checked="" type="checkbox"/>	<input checked="" type="checkbox"/>	<input checked="" type="checkbox"/>
5.	<input type="radio"/>	<input type="radio"/>	<input type="radio"/>	<input type="radio"/>	<input type="radio"/>	<input checked="" type="radio"/>	<input type="checkbox"/>	<input type="checkbox"/>	<input type="checkbox"/>

Notes: One mark each. Responses must be indicated clearly.

GRM/ VCB 1 (2.5 mks)								
	bowl	mirror	hand	torch	ladder	scissors	rug	compass
1.	<input type="radio"/>	<input type="radio"/>	<input checked="" type="radio"/>	<input type="radio"/>	<input type="radio"/>	<input type="radio"/>	<input type="radio"/>	<input type="radio"/>
2.	<input type="radio"/>	<input type="radio"/>	<input type="radio"/>	<input type="radio"/>	<input type="radio"/>	<input checked="" type="radio"/>	<input type="radio"/>	<input type="radio"/>
3.	<input type="radio"/>	<input type="radio"/>	<input type="radio"/>	<input type="radio"/>	<input type="radio"/>	<input type="radio"/>	<input type="radio"/>	<input checked="" type="radio"/>
4.	<input checked="" type="radio"/>	<input type="radio"/>	<input type="radio"/>	<input type="radio"/>	<input type="radio"/>	<input type="radio"/>	<input type="radio"/>	<input type="radio"/>
5.	<input type="radio"/>	<input type="radio"/>	<input type="radio"/>	<input type="radio"/>	<input checked="" type="radio"/>	<input type="radio"/>	<input type="radio"/>	<input type="radio"/>

Notes: Half-a-mark each. Responses must be indicated clearly.

GRM/ VCB 2 (2.5 mks)		GRM/ VCB 3 (5 mks)	
6. He		11. <u>you</u>	16. sil <u>ver</u>
7. and		12. khan <u>jar</u>	17. wh <u>ere</u>
8. at		13. <u>nice</u>	18. sh <u>op</u>
9. It		14. craft <u>t</u>	19. tak <u>e</u>
10. am		15. <u>of</u>	20. Th <u>ank</u>

Notes: Half-a-mark each. Spelling must be correct, including grammatical endings.

READING 1 (5 mks)		READING 2 (5 mks)	
1.	<input type="radio"/> He is watching a TV program. <input type="radio"/> He is swimming in the sea. <input checked="" type="radio"/> He is fishing at the river.	6.	True: <input type="radio"/> False: <input checked="" type="radio"/>
2.	<input type="radio"/> They are listening to music. <input type="radio"/> They are taking some photos. <input checked="" type="radio"/> They are growing trees.	7.	True: <input type="radio"/> False: <input checked="" type="radio"/>
3.	<input checked="" type="radio"/> The boy is eating popcorn. <input type="radio"/> The boy is playing with his sister. <input type="radio"/> The boy is writing his math homework.	8.	True: <input checked="" type="radio"/> False: <input type="radio"/>
4.	<input type="radio"/> They are studying in the school. <input checked="" type="radio"/> They are making an iceman. <input type="radio"/> They are climbing a mountain	9.	True: <input type="radio"/> False: <input checked="" type="radio"/>
5.	<input checked="" type="radio"/> She is cooking dinner for her family. <input type="radio"/> She is reading a book about sport. <input type="radio"/> She is writing an e-mail to her sister.	10.	True: <input type="radio"/> False: <input checked="" type="radio"/>
<i>Notes: One mark each. Responses must be indicated <u>clearly</u>.</i>		11.	True: <input checked="" type="radio"/> False: <input type="radio"/>
		12.	True: <input type="radio"/> False: <input checked="" type="radio"/>
		13.	True: <input checked="" type="radio"/> False: <input type="radio"/>
		14.	True: <input checked="" type="radio"/> False: <input type="radio"/>
		15.	True: <input checked="" type="radio"/> False: <input type="radio"/>
<i>Notes: One mark each. Responses must be indicated <u>clearly</u>.</i>		<i>Notes: Half-a-mark each. Responses must be indicated <u>clearly</u>.</i>	

WRITING 1 (2 mks)		Criteria:
2	Very good.	Consider the overall quality of the punctuation and use of capital letters in the two sentences as a whole : – Have all the correct punctuation marks and capital letters been inserted in the correct places? – Have any been inserted that should <u>not</u> be there? Sentence A: <u>M</u>y best friends are <u>A</u>isha and <u>F</u>atima. Sentence B: <u>W</u>hat are you doing here?
1.5	Good.	
1	Adequate. (Just good enough)	
0.5	Inadequate. (Not good enough)	
0	No attempt at the task.	
###	#####	
###	#####	

WRITING 2 (3 mks)		Criteria:
3	Very good.	<p>Consider the overall quality of the three sentences as a whole:</p> <p>– Do the sentences <u>make sense</u>? [<i>Is the meaning clear?</i>]</p> <p>– How much <u>relevant information</u> do the sentences communicate? [<i>Are the sentences extremely simple, or does the student try to say a little more about the pictures?</i>]</p> <p>– Is the <u>language</u> in the sentences <u>correct</u>? [<i>Is the grammar/ vocabulary/ spelling/ punctuation (mostly) correct?</i>]</p>
2.5	Good.	
2	Quite good.	
1.5	Adequate. (Just good enough)	
1	Inadequate. (Not good enough)	
0.5	A <u>very</u> weak attempt at the task.	
0	No attempt at the task.	

WRITING 3 (5 mks)	
5	<ul style="list-style-type: none"> – Task achievement is <u>very good</u>. – Meaning is very clear. – Grammar/ Vocab are correct and appropriate. – Spelling and punctuation are very good.
4	<ul style="list-style-type: none"> – Task achievement is <u>good</u>. – Meaning is almost always clear. – Grammar/ Vocab are mostly correct and appropriate. – Spelling and punctuation are good.
3	<ul style="list-style-type: none"> – Task achievement is <u>adequate</u>. – Meaning is clear enough. – Grammar/ Vocab are reasonably correct and appropriate. – Spelling and punctuation are reasonably good.
2	<ul style="list-style-type: none"> – Task achievement is <u>inadequate</u>. – Meaning is sometimes unclear. – Grammar/ Vocab are quite often incorrect or inappropriate. – Spelling and punctuation are often inaccurate.
1	<ul style="list-style-type: none"> – Task achievement is <u>poor</u>. – Meaning is often unclear. – Grammar/ Vocab are very often incorrect and inappropriate. – Spelling and punctuation are very poor.
0	<p><u>No attempt at the task</u>: <u>EITHER</u> Irrelevant (Completely unrelated to the task/ instructions) <u>OR</u> Just copied from the Q-paper <u>OR</u> Hardly any writing at all, or not written in English <u>OR</u> Complete nonsense</p>

Listening scripts

G6, semester1-session1

Listening 1: You are going to hear five short texts about people talking about their jobs. Match the pictures with the texts. For each text, shade in the bubble under the correct option.

1. I'm Khalid and because of my work people call me the hero. I rescue people from the fire. I use water to fight the fire.
2. I always take my camera with me. I like taking photos of people and flowers. Last year I won a prize for the best photo.
3. Hello, My name is Sheikha. I like my work. I help sick people to become better by giving them medicine.
4. My name is Mohammed. I use special maps in my work. My dream is to design the tallest building in the world.
5. Hi, I am Adel. I like my job because, I fly like birds and watch the sky. I wish to travel around the world.

Listening 2: You are going to hear Ali talking about the sports' club in his city

Listen and tick (✓) if you can play the sport in the club or cross (×) if you can't. The first picture is an example..

Hello everyone, I am Ali from Muscat. Today I want to tell you about our sport club in my city. The club has different activities and sports. The most popular sport is football because many people like it. Unfortunately, we do not have a swimming pool so we cannot swim there. We enjoy playing tennis in the lovely tennis court. If you are a new member and like running, you will enjoy it in the running line but sadly, you cannot use your bike in our club. Our new sport for this season is cricket, which you can practice in the playground. There are many friendly trainers they will help you when you need them. The club opens all days of the week.