

ENGLISH LANGUAGE TEST

GRADE EIGHT

Semester One

First Session

Name			
School		Class	

Write your answers on the Test Paper
Time: 2 hours **Pages: 10**

TEST SCORES	LISTENING	10	
	GRM/VCB	10	
	READING	10	
	WRITING	10	
	TOTAL	40	

LISTENING 1 (Items 1–5)

[5 marks]

You are going to hear five short texts about inventions. Match the pictures with the texts. For each text, shade in the bubble under the correct option.

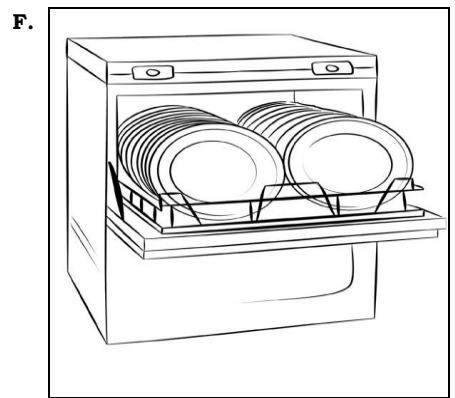
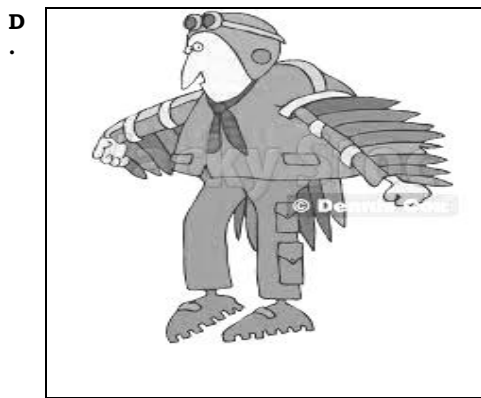
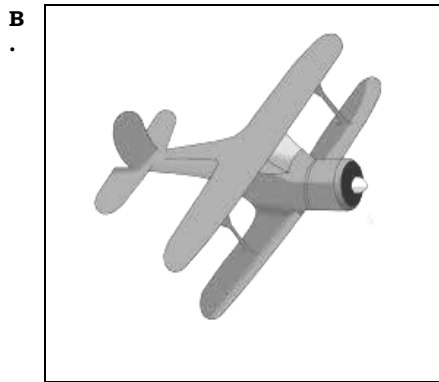
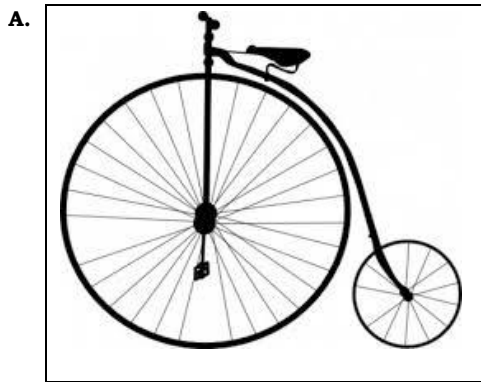

Pictures

Text	A	B	C	D	E	F
1.	<input type="radio"/>	<input type="radio"/>	<input type="radio"/>	<input type="radio"/>	<input type="radio"/>	<input type="radio"/>
2.	<input type="radio"/>	<input type="radio"/>	<input type="radio"/>	<input type="radio"/>	<input type="radio"/>	<input type="radio"/>
3.	<input type="radio"/>	<input type="radio"/>	<input type="radio"/>	<input type="radio"/>	<input type="radio"/>	<input type="radio"/>
4.	<input type="radio"/>	<input type="radio"/>	<input type="radio"/>	<input type="radio"/>	<input type="radio"/>	<input type="radio"/>
5.	<input type="radio"/>	<input type="radio"/>	<input type="radio"/>	<input type="radio"/>	<input type="radio"/>	<input type="radio"/>



LISTENING 2 (Items 6–10)**[5 marks]**

You are going to hear a talk about London Zoo.

For each item, shade in the bubble next to the correct option.

6. London Zoo was opened in _____.

 1828 1955 1958

7. The zoo has _____ different species of animals.

 65 150 750

8. A _____ was brought to the zoo from China.

 giraffe panda tiger

9. _____ was opened in 1965 in the zoo.

 A fish aquarium An animal hospital A reptile house

10. Visitors can see animal shows every _____.

 day week month

--

**LISTENING
SCORE**

10

GRAMMAR/VOCABULARY 1 (Items 1–5)

[2½ marks]

Complete the text. For each item, shade in the bubble next to the correct option.

Professor Nutkin is an inventor. He loves his job because he ⁽¹⁾ _____ new things. Every morning, he goes to his lab and ⁽²⁾ _____ on his inventions. In his free time, he ⁽³⁾ _____ going to the cinema to see science-fiction films. He also ⁽⁴⁾ _____ a lot of time on his computer. In the afternoon, he goes to the park for a walk. He often ⁽⁵⁾ _____ ideas for his inventions while walking in the park.

- | | | |
|--|---|---|
| <p>1. makes
<input type="radio"/></p> | <p>meets
<input type="radio"/></p> | <p>stays
<input type="radio"/></p> |
| <p>2. finds
<input type="radio"/></p> | <p>takes
<input type="radio"/></p> | <p>works
<input type="radio"/></p> |
| <p>3. arrives
<input type="radio"/></p> | <p>enjoys
<input type="radio"/></p> | <p>joins
<input type="radio"/></p> |
| <p>4. sends
<input type="radio"/></p> | <p>spends
<input type="radio"/></p> | <p>stands
<input type="radio"/></p> |
| <p>5. gets
<input type="radio"/></p> | <p>leaves
<input type="radio"/></p> | <p>sticks
<input type="radio"/></p> |

GRAMMAR/VOCABULARY 2 (Items 6–10)

[2½ marks]

Complete each sentence with **ONE** word only.

- 6.** My camera _____ stolen while I was on holiday.
- 7.** If you go to the park, you _____ see the celebration.
- 8.** She is two years older _____ me.
- 9.** I _____ already finished the report.
- 10.** She used _____ play the piano, but now she plays the guitar.

GRAMMAR/VOCABULARY 3 (Items 11–20)**[5 marks]**

Complete the unfinished words in the text.
Make sure you **spell** each word **correctly**.

EXAMPLE:

“Good morning! My name’s Ahmed Al-Zedjali and I’m a student at a school in Muscat. I’m in Grade Six. My favourite subject is Maths.”

TEXT

Speaker A: Hi, Kamal! Is this yo_____ shop?

Speaker B: No, it's m____ father's shop and I he_____ him.

Speaker A: Oh! What ti_____ do you get up?

Speaker B: I get up at 6.30 every mor_____.

Speaker A: That's early! Ok, I want a kilo o____ mangoes, ple_____.

Speaker B: These a____ good mangoes. They are grown i____ Oman.

Speaker A: Really?! That's gr_____! Then give me two kilos!

**GRM/VCB
SCORE**

10

READING 1 (Items 1–4)

[4 marks]

Match the four texts on the left with the texts in the box. Shade in the bubble under the correct option.

- 1. I'm having a great time here with my brother in England.
- 2. Maryam took lots of photographs when she travelled to Australia.
- 3. Just before dawn each morning, the streets are clean.
- 4. My mother told me about how she got the first television when she was a teenager.

A. But by the end of the day, there is enough rubbish to fill a swimming pool.
B. It was very long and all the children slept on their chairs and tables.
C. I think it is the most interesting place I have ever visited.
D. She taught me lots of things about natural history and wild animals.
E. I saw her album. It is almost full.
F. It was black and white, and she watched it only at night.

A	B	C	D	E	F
---	---	---	---	---	---

1.	<input type="radio"/>	<input type="radio"/>	<input type="radio"/>	<input type="radio"/>	<input type="radio"/>	<input type="radio"/>
2.	<input type="radio"/>	<input type="radio"/>	<input type="radio"/>	<input type="radio"/>	<input type="radio"/>	<input type="radio"/>
3.	<input type="radio"/>	<input type="radio"/>	<input type="radio"/>	<input type="radio"/>	<input type="radio"/>	<input type="radio"/>
4.	<input type="radio"/>	<input type="radio"/>	<input type="radio"/>	<input type="radio"/>	<input type="radio"/>	<input type="radio"/>

READING 2 (Items 5–10)**[6 marks]**

Read the text. Then complete the task.

Dear Mum and Dad,

I've just found some time to write. Scotland is fantastic. John and I are busy visiting places.

The flight on Thursday night was eight hours long, so we arrived here on Friday morning. We took our bags to the hotel and immediately went on a tour around the city centre. We visited the fort first and then had coffee in a café. We went to the Royal Botanic Garden yesterday to collect some information about flowers for John's school project. We, then, visited the National Museum. I thought it was amazing with all those interesting displays but John liked the garden more. We haven't tried any traditional food yet. We were thinking of having dinner in a local restaurant tonight but fortunately a Scottish friend has invited us to his house tonight to try some of their food tonight.

Scotland is also great for shopping. We've already bought a lot of souvenirs and gifts for everyone. We know mum loves cooking, so we bought her a nice cook book. King Street, where most of the shops are, is the busiest street we have ever seen!

Anyway, I have to go now. I'll write back soon.

Lots of love,

Mary

READING 2 (cont'd)

For each question, write a short answer (**not more than THREE WORDS**).

5. Which country did John and Mary visit?

6. When did they arrive there?

7. What is John's project about?

8. What was Mary's favourite place?

9. Where are they going to eat some traditional food?

10. What did they get their mother as a gift?

**READING
SCORE**

10

WRITING 2

[5 marks]

Write a story of at least **60 words** based on the following pictures.

You can use the words in the box to help you.

You can also put in more details to make your story lively and interesting.

drive fast	think	late	birthday party
weather	rain	accident	hospital

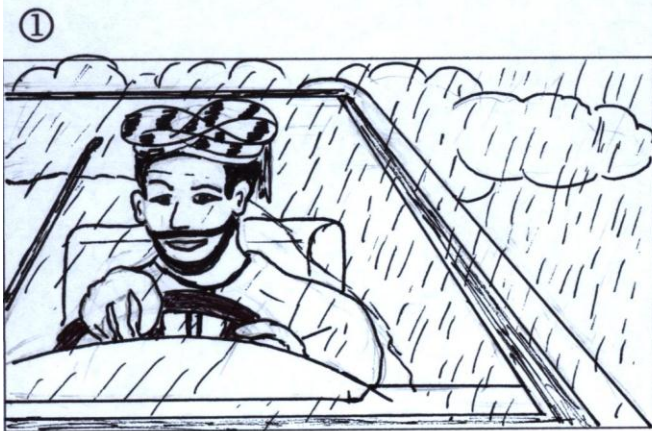

Marker A	Marker B	Average

**WRITING
SCORE**

10

ENGLISH LANGUAGE TEST

LISTENING SCRIPT

GRADE EIGHT

Semester One

First Session

LISTENING 1

You are going to hear five short texts about inventions. Match the pictures with the texts. For each text, shade in the bubble under the correct option. First, you have 30 seconds to look the pictures.

1. This invention can help in keeping your carpets, rugs and floor clean. It is easy to move it everywhere with your hands, but it is noisy.
2. This is the best way to fly in the air. It helps people travel from one country to another quickly and easily.
3. This is the best choice for people who like fresh air. You only need to control and balance yourself using two different wheels; one big and one small.
4. This invention helps in cleaning the dishes and plates easily and safely. It can work with electricity or gas, but it needs lots of water.
5. These inventions are helpful in measuring the temperature and knowing the weather. It is good for people who usually like to go out to decide which clothes to wear.

LISTENING 2

You are going to hear a talk about London Zoo.

For each item, shade in the bubble next to the correct option. First, you have 30 seconds to read the questions.

London zoo is the world's oldest scientific zoo. It can be found in the middle of London.

The zoo was first opened in 1828 but it was renewed in 1955. It is about 150,000 square metre. It has a lot of animals to see including lions, camels, giraffes, penguins, tigers and monkeys. In fact, there are 750 different species of animals making it one of the largest collections of animals in the world. The famous giant panda Chi-Chi arrived there from China in 1958.

The zoo has also a reptile house, a fish aquarium and an animal hospital. The hospital was built in 1965. The zoo is divided up into many different areas which are great fun to explore and help make it one of Britain's most popular tourist attractions.

There are also animals' shows which are held every day. Here, visitors can learn more about the animals from their keepers. There is also a children's zoo where children can feed and touch the goats and sheep and meet the donkeys and llamas.

LISTENING 1 (5 mks)						
	A	B	C	D	E	F
1.	<input type="radio"/>	<input type="radio"/>	<input type="radio"/>	<input type="radio"/>	<input checked="" type="radio"/>	<input type="radio"/>
2.	<input type="radio"/>	<input checked="" type="radio"/>	<input type="radio"/>	<input type="radio"/>	<input type="radio"/>	<input type="radio"/>
3.	<input checked="" type="radio"/>	<input type="radio"/>	<input type="radio"/>	<input type="radio"/>	<input type="radio"/>	<input type="radio"/>
4.	<input type="radio"/>	<input type="radio"/>	<input type="radio"/>	<input type="radio"/>	<input type="radio"/>	<input checked="" type="radio"/>
5.	<input type="radio"/>	<input type="radio"/>	<input checked="" type="radio"/>	<input type="radio"/>	<input type="radio"/>	<input type="radio"/>

Notes: One mark each. Responses must be indicated clearly.

LISTENING 2 (5 mks)			
6.	<input checked="" type="radio"/> 1828	<input type="radio"/> 1955	<input type="radio"/> 1958
7.	<input type="radio"/> 65	<input type="radio"/> 150	<input checked="" type="radio"/> 750
8.	<input type="radio"/> giraffe	<input checked="" type="radio"/> panda	<input type="radio"/> tiger
9.	<input type="radio"/> A fish aquarium	<input checked="" type="radio"/> An animal hospital	<input type="radio"/> A reptile house
10.	<input checked="" type="radio"/> day	<input type="radio"/> week	<input type="radio"/> month

Notes: One mark each. Responses must be indicated clearly.

GRM/ VCB 1 (2.5 mks)			
1.	<input checked="" type="radio"/> makes	<input type="radio"/> meets	<input type="radio"/> stays
2.	<input type="radio"/> finds	<input type="radio"/> takes	<input checked="" type="radio"/> works
3.	<input type="radio"/> arrives	<input checked="" type="radio"/> enjoys	<input type="radio"/> joins
4.	<input type="radio"/> sends	<input checked="" type="radio"/> spends	<input type="radio"/> stands
5.	<input checked="" type="radio"/> gets	<input type="radio"/> leaves	<input type="radio"/> sticks

Notes: Half-a-mark each. Responses must be indicated clearly.

GRM/ VCB 2 (2.5 mks)	GRM/ VCB 3 (5 mks)	
6. was 7. will 8. than 9. have 10. to	11. yo <u>ur</u> 12. m <u>y</u> 13. he <u>lp</u> 14. ti <u>me</u> 15. mor <u>ning</u>	16. o <u>f</u> 17. ple <u>ase</u> 18. a <u>re</u> 19. i <u>n</u> 20. g <u>reat</u>
<i>Notes: Half-a-mark each. Spelling <u>must</u> be correct.</i>	<i>Notes: Half-a-mark each. Spelling <u>must</u> be correct, including grammatical endings.</i>	

READING 1 (4 mks)	READING 2 (6 mks)																																			
<table border="0"> <tr> <td></td> <td style="text-align: center;">A</td> <td style="text-align: center;">B</td> <td style="text-align: center;">C</td> <td style="text-align: center;">D</td> <td style="text-align: center;">E</td> <td style="text-align: center;">F</td> </tr> <tr> <td style="text-align: right;">1.</td> <td style="text-align: center;"><input type="radio"/></td> <td style="text-align: center;"><input type="radio"/></td> <td style="text-align: center;"><input checked="" type="radio"/></td> <td style="text-align: center;"><input type="radio"/></td> <td style="text-align: center;"><input type="radio"/></td> <td style="text-align: center;"><input type="radio"/></td> </tr> <tr> <td style="text-align: right;">2.</td> <td style="text-align: center;"><input type="radio"/></td> <td style="text-align: center;"><input type="radio"/></td> <td style="text-align: center;"><input type="radio"/></td> <td style="text-align: center;"><input type="radio"/></td> <td style="text-align: center;"><input checked="" type="radio"/></td> <td style="text-align: center;"><input type="radio"/></td> </tr> <tr> <td style="text-align: right;">3.</td> <td style="text-align: center;"><input checked="" type="radio"/></td> <td style="text-align: center;"><input type="radio"/></td> <td style="text-align: center;"><input type="radio"/></td> <td style="text-align: center;"><input type="radio"/></td> <td style="text-align: center;"><input type="radio"/></td> <td style="text-align: center;"><input type="radio"/></td> </tr> <tr> <td style="text-align: right;">4.</td> <td style="text-align: center;"><input type="radio"/></td> <td style="text-align: center;"><input type="radio"/></td> <td style="text-align: center;"><input type="radio"/></td> <td style="text-align: center;"><input type="radio"/></td> <td style="text-align: center;"><input type="radio"/></td> <td style="text-align: center;"><input checked="" type="radio"/></td> </tr> </table>		A	B	C	D	E	F	1.	<input type="radio"/>	<input type="radio"/>	<input checked="" type="radio"/>	<input type="radio"/>	<input type="radio"/>	<input type="radio"/>	2.	<input type="radio"/>	<input type="radio"/>	<input type="radio"/>	<input type="radio"/>	<input checked="" type="radio"/>	<input type="radio"/>	3.	<input checked="" type="radio"/>	<input type="radio"/>	<input type="radio"/>	<input type="radio"/>	<input type="radio"/>	<input type="radio"/>	4.	<input type="radio"/>	<input type="radio"/>	<input type="radio"/>	<input type="radio"/>	<input type="radio"/>	<input checked="" type="radio"/>	5. Scotland 6. Friday morning 7. flowers 8. The National Museum 9. A friend's house 10. Cook book
	A	B	C	D	E	F																														
1.	<input type="radio"/>	<input type="radio"/>	<input checked="" type="radio"/>	<input type="radio"/>	<input type="radio"/>	<input type="radio"/>																														
2.	<input type="radio"/>	<input type="radio"/>	<input type="radio"/>	<input type="radio"/>	<input checked="" type="radio"/>	<input type="radio"/>																														
3.	<input checked="" type="radio"/>	<input type="radio"/>	<input type="radio"/>	<input type="radio"/>	<input type="radio"/>	<input type="radio"/>																														
4.	<input type="radio"/>	<input type="radio"/>	<input type="radio"/>	<input type="radio"/>	<input type="radio"/>	<input checked="" type="radio"/>																														
<i>Notes: One mark each. Responses must be indicated <u>clearly</u>.</i>	<i>Notes: One mark each. Complete accuracy in grammar and spelling is not required, but answers must be <u>clearly</u> and <u>convincingly</u> correct.</i>																																			

WRITING 1 (5 mks)	
5	<ul style="list-style-type: none"> – Discusses the topic in a lively, interesting way, making effective use of supporting arguments. – The points made by the writer are logically organised and very clear. – Makes use of a fair range of structures and vocabulary, with a good level of accuracy.
4	<ul style="list-style-type: none"> – Discusses the topic reasonably well, but use of supporting arguments is not fully effective. – The points made by the writer are reasonably well organized and mostly clear. – Use of grammar and vocabulary is reasonably correct, though rather limited in range.
3	<ul style="list-style-type: none"> – Expresses opinions with some use of supporting arguments, but only in a limited way. – The writer makes an attempt to organise his/her points, but this is only partly effective. – There is a noticeable lack of accuracy in the use of grammar and vocabulary.
2	<ul style="list-style-type: none"> – Makes an attempt to discuss the topic, but the result is unconvincing and clearly inadequate. – Weak organization makes it difficult to follow the points being made by the writer. – Grammar and vocabulary contain frequent serious errors.
1	<ul style="list-style-type: none"> – A <u>very</u> feeble attempt to discuss the topic. Very little relevant content. – The points made by the writer are confused and disjointed. – The language used is extremely limited and/or seriously distorted.
0	<u>No attempt at the task</u> : EITHER Irrelevant (Completely unrelated to the topic) OR Hardly any writing at all, or not written in English OR Complete nonsense

WRITING 2 (5 mks)	
5	<ul style="list-style-type: none"> – Tells the story fully and clearly, in a lively, interesting way, providing appropriate details. – The text is coherent and easy to read. Not many language errors.
4	<ul style="list-style-type: none"> – Tells the story clearly enough, but writing lacks interest for the reader. – There are several noticeable language errors and the text sometimes lacks coherence.
3	<ul style="list-style-type: none"> – Manages to convey the main outline of the story, but only in a limited way. – Language used is limited in range and/or contains quite frequent errors.
2	<ul style="list-style-type: none"> – An attempt is made to tell the story, but important points are either missing or unclear. – Language used is very limited and/or contains many serious errors.
1	<ul style="list-style-type: none"> – A <u>very</u> feeble attempt to tell the story. Very little relevant content. – Language used is extremely limited and/or seriously distorted.
0	<u>No attempt at the task</u> : EITHER Irrelevant (Completely unrelated to the pictures/ task/ instructions) OR Hardly any writing at all, or not written in English OR Complete nonsense

* **NOTE:** In WRITING 2, test-writers actually have two different task-options to choose from (**Picture Story** or **Task Instructions**) when preparing the exam-paper. However, as both of these require student to produce a **narrative** text, the same Rating Scale can be used, whichever type of task they use.