

# Listening Script

GRADE FIVE

Semester Two

Second Session

**LISTENING ١ (Items ١-٥)**

**(٥ marks)**

You're going to hear five short texts about **jobs**. For each text, there is one statement. Is each statement **True** or **False**? Listen, and shade in the bubble  under the correct option.

١. Nadia works in a wonderful school. She teaches Science. She enjoys making experiments with her students.
  ٢. Khalid likes gardening. He spends his day caring of his plants and trees. He likes growing vegetables.
  ٣. Amal works in a big hospital. She looks after sick children. She is an active nurse who loves her job.
  ٤. Faisal is a policeman. He works in a big police station. He drives to his job by the police car.
  ٥. Salim is a friendly shopkeeper. He works in a big bookshop. He sells books and magazines.
- 

**LISTENING ٢ (Items ٦-١٠)**

**(٥ marks)**

You're going to hear **a text** about **Ali's day**.

Listen and for each item, shade in the bubble  next to the correct option.

One day Ali and his family decided to have a picnic on the beach. They all were excited and woke up early to prepare for the picnic.

Ali's father drove to the beach and they arrived at ١٠ o'clock in the morning. Ali and his brother played football. Then they had their lunch which was made by their mother and it was so tasty.

Ali went for a walk and suddenly he found a bird was stuck under a seashell. First, Ali was frightened but then he pulled the bird gently. He helped the bird and put it on a branch of a tree. The bird moved its wings and flew to its nest. Ali felt very happy when he saw the bird flying freely.

**ENGLISH LANGUAGE TEST**

**GRADE FIVE**

**Semester Two  
Second Session**

<b>Name</b>			
<b>School</b>		<b>Class</b>	

**Write your answers on the Test Paper**

**Time: 1½ hours**

**Pages: 4**

<b>TEST SCORES</b>	<b>LISTENING</b>	١٠	
	<b>GRM/VCB</b>	١٠	
	<b>READING</b>	١٠	
	<b>WRITING</b>	١٠	
	<b>TOTAL</b>	<b>٤٠</b>	

**LISTENING ١ (Items ١-٥)****(٥ marks)**

You're going to hear five short texts about **jobs**.

For each text, there is one statement. Is each statement **True** or **False**?

Listen, and shade in the bubble  under the correct option.

**Statements**

True	False
------	-------

١. Nadia is a student.

<input type="radio"/>	<input type="radio"/>
-----------------------	-----------------------

٢. Khalid works in a farm.

<input type="radio"/>	<input type="radio"/>
-----------------------	-----------------------

٣. Amal enjoys her work.

<input type="radio"/>	<input type="radio"/>
-----------------------	-----------------------

٤. Faisal cycles to his job.

<input type="radio"/>	<input type="radio"/>
-----------------------	-----------------------

٥. Salim sells books.

<input type="radio"/>	<input type="radio"/>
-----------------------	-----------------------

--

**LISTENING ٢ (Items ٦-١٠)****(٥ marks)**

You're going to hear **a text** about **Ali's day**.

Listen and for each item, shade in the bubble  next to the correct option.

٦. The main idea is \_\_\_\_\_.
- helping animals       playing football       making lunch
٧. The family reached the beach in the \_\_\_\_\_.
- afternoon       evening       morning
٨. The lunch was prepared by the \_\_\_\_\_.
- brother       father       mother
٩. Ali found a bird under a \_\_\_\_\_.
- nest       seashell       tree
١٠. At the end, Ali was \_\_\_\_\_.
- angry       glad       scared

**LISTENING  
SCORE**

<input type="text"/>
١٠

**GRAMMAR/VOCABULARY ١ (Items ١-٥)**

**(٢½ marks)**

*Under each picture, write the correct word, as in the example.*

e.g.

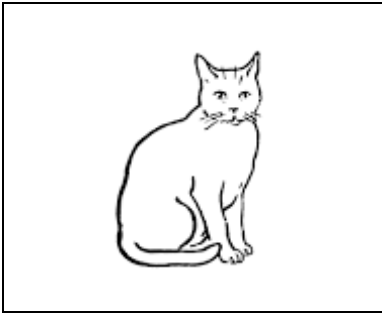

c a t

١.

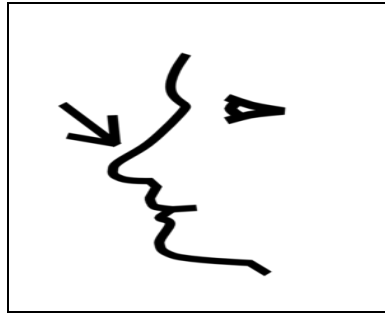

-----

٢.

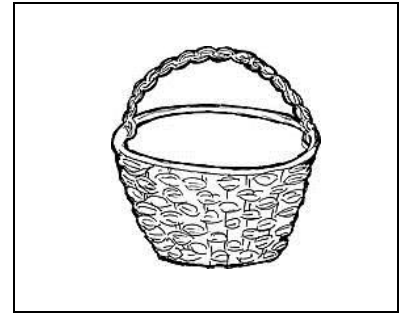

-----

٣.

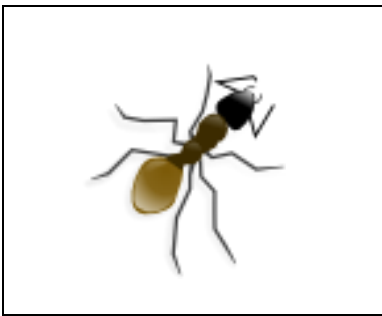

-----

٤.

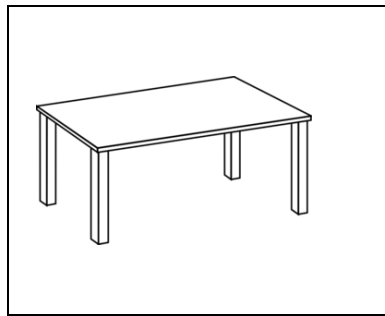

-----

٥.

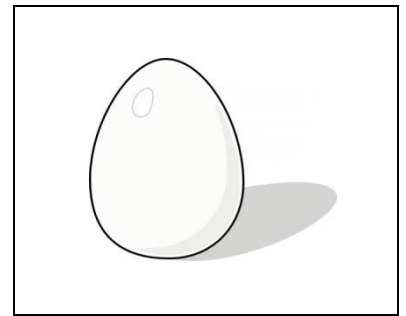

-----



**GRAMMAR/VOCABULARY ٢ (Items ٦-١٠)****(٢ ½ marks)**

For each item, shade in the bubble  next to the correct option.

٦. I go to school \_\_\_\_\_ ٧ o'clock.

- at                       for                       of                       on

٧. Ahmed is shorter \_\_\_\_\_ Sami.

- than                       them                       then                       this

٨. \_\_\_\_\_ is the capital city of Qatar? It's Doha.

- What                       When                       Who                       Why

٩. Farah likes \_\_\_\_\_ stories.

- write                       writing                       written                       wrote

١٠. Naila \_\_\_\_\_ doing her homework now.

- am                       are                       is                       were

**GRAMMAR/VOCABULARY ٣ (Items ١١-٢٠)****(٥ marks)**

Complete the unfinished words in the text.  
Make sure you **spell** each word **correctly**.

**EXAMPLE:**

"Good morning! My name's Ahmed Al-Zedjali and I'm a student at a school in Muscat. I'm in Grade Six. My favourite subject is Maths."

**TEXT**

A tiger is a **str**\_\_\_\_\_ animal. It **ha**\_\_\_\_\_ a big body with a long tail. Tigers **li**\_\_\_\_\_ in forests and grasslands. Most **o**\_\_\_\_\_ them are orange with **bl**\_\_\_\_\_ stripes. Tigers **u**\_\_\_\_\_ their sharp teeth and paws **t**\_\_\_\_\_ catch animals and **e**\_\_\_\_\_ their meat. Tigers **c**\_\_\_\_\_ swim in **t**\_\_\_\_\_ water easily.

**GRM/VCB  
SCORE**

١٠

**READING ١ (Items ١-٥)**

**(٥ marks)**

Match the texts with the pictures. For each text, shade in the bubble  under the correct option.

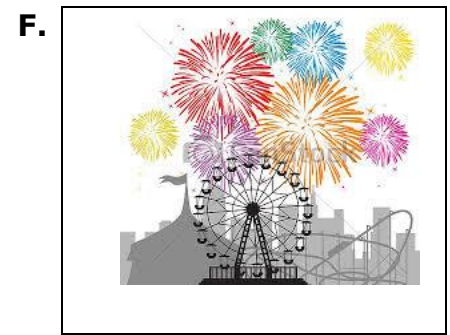
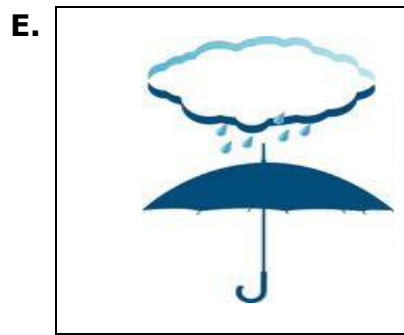
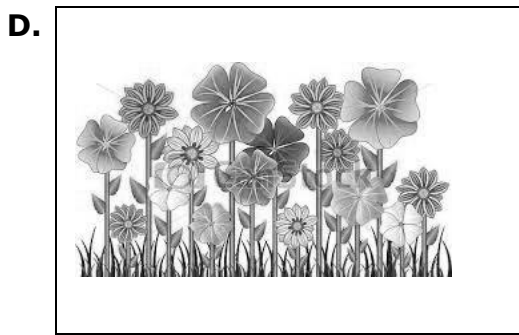
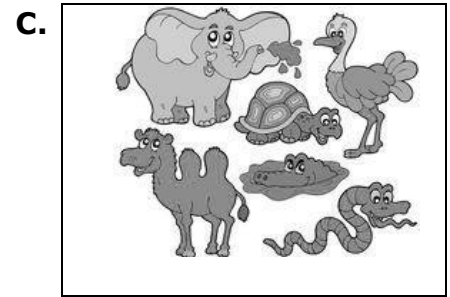

**Pictures**

**Texts**

A	B	C	D	E	F
---	---	---	---	---	---

١. Last summer I went to London. I enjoyed the raining weather there. It was a chance to use my umbrella.
٢. My friends and I visited the zoo. We saw different animals and birds. It was a wonderful day.
٣. I visited Dubai last holiday. I went to the funfair and I saw the fireworks. It was a fantastic time.
٤. I was interested last time when I visited Egypt with my brothers. We saw the great pyramids.
٥. I love flowers, so I decided to visit Thailand. I went to the rose garden and spent lovely time there.

<input type="radio"/>	<input type="radio"/>	<input type="radio"/>	<input type="radio"/>	<input type="radio"/>	<input type="radio"/>
<input type="radio"/>	<input type="radio"/>	<input type="radio"/>	<input type="radio"/>	<input type="radio"/>	<input type="radio"/>
<input type="radio"/>	<input type="radio"/>	<input type="radio"/>	<input type="radio"/>	<input type="radio"/>	<input type="radio"/>
<input type="radio"/>	<input type="radio"/>	<input type="radio"/>	<input type="radio"/>	<input type="radio"/>	<input type="radio"/>
<input type="radio"/>	<input type="radio"/>	<input type="radio"/>	<input type="radio"/>	<input type="radio"/>	<input type="radio"/>



**READING ٢ (Items ٦-١٠)****(٥ marks)**

Read the text. For each question, write a short answer (**not more than FOUR WORDS**).

Dear Fahad,

How are you? I would like to tell you about my free time activity. I spend most of my time in reading. I am reading a very useful book now. This book includes some information about the Arabian horses, it is called " Arabian horses". I really like reading it. It is written by Kate Riddle. It has some amazing pictures to enjoy. It also tells the history of the Arabian horses. And it shows different types and colours of them. This book gives some instructions about how to keep horses well. I found it in my school library. It is really an interesting book.

I would like to share the book with you so you can enjoy your time reading it.

By,

Ameen

٦. What does Ameen do in his free time?

\_\_\_\_\_

٧. What is the title of the book?

\_\_\_\_\_

٨. Who wrote the book?

\_\_\_\_\_

٩. Where did Ameen get the book from?

\_\_\_\_\_

١٠. How does Ameen feel about the book ?

\_\_\_\_\_

**READING  
SCORE**

١٠

**WRITING ١**

**(٢ marks)**

Write these two sentences correctly. Put in capital letters and punctuation marks.

**A.** i was born in april

---

**B.** who invented the car

---

Marker A	Marker B	Average

**WRITING ٢**

**(٢ marks)**

In each box, there are two words. Use the words to write **ONE** sentence.

<p><u>Example:</u></p> <p>Huda          nurse</p>	<p>Huda <i>is</i> a nurse.</p> <p><u>OR</u> Huda <i>spoke to the</i> nurse.</p> <p>(etc, etc)</p>
---	---

**A.**

live          city
--------------------

 \_\_\_\_\_

**B.**

Omar          driver
----------------------

 \_\_\_\_\_

**C.**

eat          apples
---------------------

 \_\_\_\_\_

Marker A	Marker B	Average

**WRITING 2**

**(2 marks)**

Write about the picture. Write at least 4 **words**. You can use the words in the box.

<p>grandfather</p> <p>story</p> <p>sofa</p> <p>happy</p>	
--	--

---



---



---



---



---



---



---



---



---

Marker A	Marker B	Average

<b>WRITING SCORE</b>	
	10

\*\*\*\*\*

LISTENING ١ (٥ mks)		LISTENING ٢ (٥ mks)		
True	False			
١. <input type="radio"/>	<input checked="" type="radio"/>	٦. <input checked="" type="radio"/> helping animals	<input type="radio"/> playing football	<input type="radio"/> making lunch
٢. <input checked="" type="radio"/>	<input type="radio"/>	٧. <input type="radio"/> afternoon	<input type="radio"/> evening	<input checked="" type="radio"/> morning
٣. <input checked="" type="radio"/>	<input type="radio"/>	٨. <input type="radio"/> brother	<input type="radio"/> father	<input checked="" type="radio"/> mother
٤. <input type="radio"/>	<input checked="" type="radio"/>	٩. <input type="radio"/> nest	<input checked="" type="radio"/> seashell	<input type="radio"/> tree
٥. <input checked="" type="radio"/>	<input type="radio"/>	١٠. <input type="radio"/> angry	<input checked="" type="radio"/> glad	<input type="radio"/> scared

*Notes: One mark each. Responses must be indicated clearly.*

GRM/ VCB ١ (٢,٥ mks)	GRM/ VCB ٢ (٢,٥ mks)			
١. nose	٦. <input checked="" type="radio"/> at	<input type="radio"/> for	<input type="radio"/> of	<input type="radio"/> on
٢. basket	٧. <input checked="" type="radio"/> than	<input type="radio"/> them	<input type="radio"/> then	<input type="radio"/> this
٣. ant	٨. <input checked="" type="radio"/> What	<input type="radio"/> When	<input type="radio"/> Who	<input type="radio"/> Why
٤. table	٩. <input type="radio"/> write	<input checked="" type="radio"/> writing	<input type="radio"/> written	<input type="radio"/> wrote
٥. egg	١٠. <input type="radio"/> am	<input type="radio"/> are	<input checked="" type="radio"/> is	<input type="radio"/> were

*Notes: Half-a-mark each. Spelling must be correct.*

*Notes: Half-a-mark each. Responses must be indicated clearly.*

GRM/ VCB ٣ (٥ mks)	
١١. <u>strong</u>	١٦. <u>use</u>
١٢. <u>has</u>	١٧. <u>to</u>
١٣. <u>live</u>	١٨. <u>eat</u>
١٤. <u>of</u>	١٩. <u>can</u>
١٥. <u>black</u>	٢٠. <u>the</u>

*Notes: Half-a-mark each. Spelling must be correct, including grammatical endings.*

READING 1 (5 mks)							READING 2 (5 mks)
	A	B	C	D	E	F	
1.	<input type="radio"/>	<input type="radio"/>	<input type="radio"/>	<input type="radio"/>	<input checked="" type="radio"/>	<input type="radio"/>	1. reading (books)
2.	<input type="radio"/>	<input type="radio"/>	<input checked="" type="radio"/>	<input type="radio"/>	<input type="radio"/>	<input type="radio"/>	2. Arabian horses
3.	<input type="radio"/>	<input type="radio"/>	<input type="radio"/>	<input type="radio"/>	<input type="radio"/>	<input checked="" type="radio"/>	3. Kate Riddle
4.	<input checked="" type="radio"/>	<input type="radio"/>	<input type="radio"/>	<input type="radio"/>	<input type="radio"/>	<input type="radio"/>	4. school library (library) (school)
5.	<input type="radio"/>	<input type="radio"/>	<input type="radio"/>	<input checked="" type="radio"/>	<input type="radio"/>	<input type="radio"/>	5. interesting/ enjoyable/ useful/ exciting OR any relevant answer
<p><b>Notes:</b> One mark each. Responses must be indicated <u>clearly</u>.</p>							<p><b>Notes:</b> One mark each. Ignore grammar/ spelling mistakes as long as the content of the response is <u>clearly</u> correct.</p>

WRITING 1 (2 mks)		WRITING 2 (3 mks)	
2	Very good.	3	Very good.
1,5	Good.	2,5	Good.
1	Adequate. (Just good enough)	2	Quite good.
0,5	Inadequate. (Not good enough)	1,5	Adequate. (Just good enough)
0	No attempt at the task.	1	Inadequate. (Not good enough)
		0,5	A <u>very</u> weak attempt at the task.
		0	No attempt at the task.
<b>Criteria:</b>	<p>Consider the <b>overall quality</b> of the punctuation and use of capital letters in the two sentences <b>as a whole</b>:</p> <ul style="list-style-type: none"> <li>– Have all the correct punctuation marks and capital letters been inserted in the correct places?</li> <li>– Have any been inserted that should <u>not</u> be there?</li> </ul> <p><b>Sentence A:</b> <u>I</u> was born in <u>April</u>.</p> <p><b>Sentence B:</b> <u>Who</u> invented the car?</p>	<b>Criteria:</b>	<p>Consider the <b>overall quality</b> of the three sentences <b>as a whole</b>:</p> <ul style="list-style-type: none"> <li>– Do the sentences <u>make sense</u>? [ <i>Is the meaning clear?</i> ]</li> <li>– How much <u>relevant information</u> do the sentences communicate? [ <i>Are the sentences extremely simple, or does the student try to say a little more?</i> ]</li> <li>– Is the <u>language</u> in the sentences <u>correct</u>? [ <i>Is the grammar/ vocabulary/ spelling/ punctuation (mostly) correct?</i> ]</li> </ul>

WRITING 3 (10 mks)	
10	<ul style="list-style-type: none"> <li>- Writing communicates clearly and is obviously appropriate to the picture.</li> <li>- Language is mostly correct.</li> </ul>
8	<ul style="list-style-type: none"> <li>- Writing communicates clearly enough and is appropriate to the picture.</li> <li>- However, there are some noticeable language errors.</li> </ul>
6	<ul style="list-style-type: none"> <li>- Manages to communicate some relevant information about the picture, but only in a limited way.</li> <li>- There are several very noticeable language errors.</li> </ul>
4	<ul style="list-style-type: none"> <li>- Attempts to communicate, but only with difficulty. Important points are missing or unclear.</li> <li>- Frequent language errors.</li> </ul>
2	<ul style="list-style-type: none"> <li>- A very unsatisfactory attempt at the task. Very little is communicated.</li> <li>- Language is seriously flawed.</li> </ul>
0	<p><u>No attempt at the task</u>: <u>EITHER</u> Irrelevant. (Completely unrelated to the picture)  <u>OR</u> Hardly any writing at all, or not written in English <u>OR</u> Complete nonsense</p>