

**ENGLISH LANGUAGE TEST**

**GRADE NINE**

Semester One

First Session

<b>Name</b>			
<b>School</b>		<b>Class</b>	

Write your answers on the Test Paper

Time: 2 hours                      Pages: 10

<b>TEST SCORES</b>	<b>LISTENING</b>	<b>10</b>	
	<b>GRM/VCB</b>	<b>10</b>	
	<b>READING</b>	<b>10</b>	
	<b>WRITING</b>	<b>10</b>	
	<b>TOTAL</b>	<b>40</b>	

**LISTENING 1 (Items 1-5)**

**(5 marks)**

You are going to hear five short texts about Sport. Match the pictures with the texts. For each text, shade in the bubble  under the correct option.

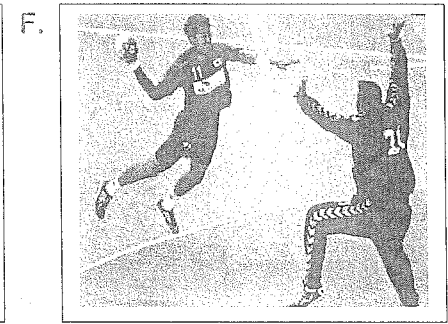
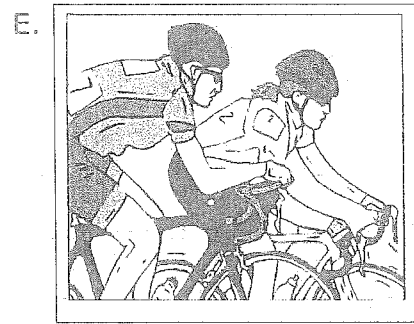
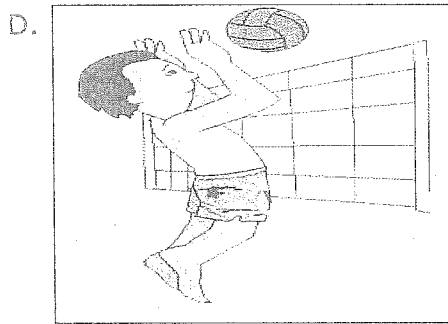
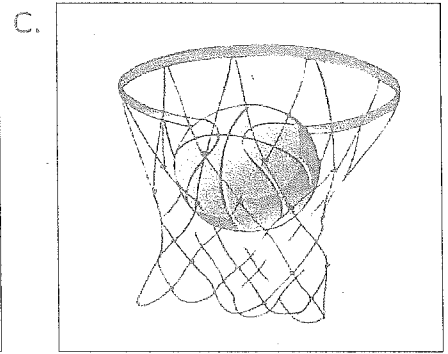
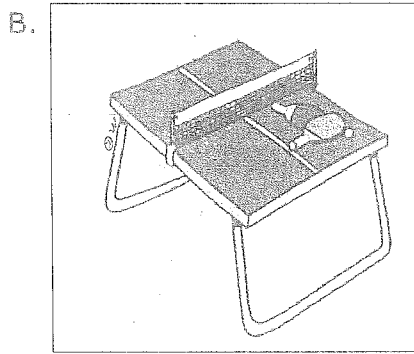
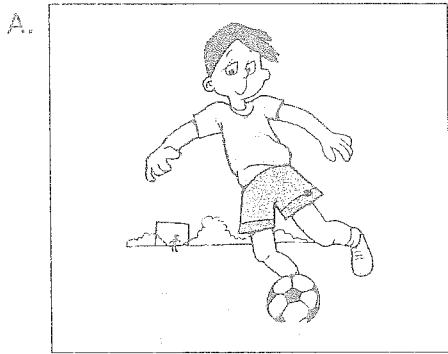

**Pictures**

Text	A	B	C	D	E	F
1.	<input type="radio"/>	<input type="radio"/>	<input type="radio"/>	<input type="radio"/>	<input type="radio"/>	<input type="radio"/>
2.	<input type="radio"/>	<input type="radio"/>	<input type="radio"/>	<input type="radio"/>	<input type="radio"/>	<input type="radio"/>
3.	<input type="radio"/>	<input type="radio"/>	<input type="radio"/>	<input type="radio"/>	<input type="radio"/>	<input type="radio"/>
4.	<input type="radio"/>	<input type="radio"/>	<input type="radio"/>	<input type="radio"/>	<input type="radio"/>	<input type="radio"/>
5.	<input type="radio"/>	<input type="radio"/>	<input type="radio"/>	<input type="radio"/>	<input type="radio"/>	<input type="radio"/>

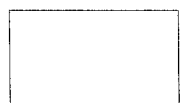

## LISTENING 2 (Items 6–10)

(5 marks)

You are going to hear a text about **Tayib Salih**, a famous Arab writer.  
For each item, shade in the bubble  next to the correct option.

6. Tayib Salih was born on 12<sup>th</sup> \_\_\_\_\_ 1929.  
 June  July  January
7. One of the jobs he had was the Head of Drama \_\_\_\_\_.  
 at Qatar Radio  at the BBC  in Paris
8. Tayib Salih's most famous writings are \_\_\_\_\_ novels.  
 two  three  four
9. His novel, 'The Wedding of Zain' won the Cannes Film Festival award in \_\_\_\_\_.  
 1969  1967  1976
10. After his death, an award that carries his name was established in Khartoum and it is open to \_\_\_\_\_.  
 everybody  Khartoum students  international students only

LISTENING  
SCORE

10

## GRAMMAR/VOCABULARY 1 (Items 1-5)

(2½ marks)

Complete the text. For each item, shade in the bubble  next to the correct option.

The environment is facing many (1) \_\_\_\_\_ now. The world population is increasing quickly, so there will be more and more people. They will need more food or there will be (2) \_\_\_\_\_ and many people may die because of hunger. The governments should grow more crops. They should also provide (3) \_\_\_\_\_ for sick people. People should co-operate to (4) \_\_\_\_\_ the environment. We should be (5) \_\_\_\_\_ about endangered animals otherwise they will become extinct and the balance of the environment will be destroyed.

- |    |                       |          |                       |              |                       |           |
|----|-----------------------|----------|-----------------------|--------------|-----------------------|-----------|
| 1. | <input type="radio"/> | dangers  | <input type="radio"/> | achievements | <input type="radio"/> | features  |
| 2. | <input type="radio"/> | diseases | <input type="radio"/> | adventures   | <input type="radio"/> | famines   |
| 3. | <input type="radio"/> | clothes  | <input type="radio"/> | exams        | <input type="radio"/> | medicines |
| 4. | <input type="radio"/> | protect  | <input type="radio"/> | employ       | <input type="radio"/> | respect   |
| 5. | <input type="radio"/> | generous | <input type="radio"/> | careless     | <input type="radio"/> | careful   |

## GRAMMAR/VOCABULARY 2 (Items 6-10)

(2½ marks)

Complete each sentence with **ONE** word only.

6. We can't go outside now. It \_\_\_\_\_ raining out there.
7. This car is very nice, \_\_\_\_\_ I don't like its colour.
8. Hilal's cap is more beautiful \_\_\_\_\_ Ahmed's cap.
9. That is the teacher \_\_\_\_\_ taught me English last year.
10. There was no food in the fridge. We \_\_\_\_\_ eaten it all.

## GRAMMAR/VOCABULARY 3 (Items 11-20)

(5 marks)

Complete the unfinished words in the text.

Make sure you **spell** each word **correctly**.

EXAMPLE:

"Good morning! My name's Ahmed Al-Zedjali and I'm a student at a school in Muscat. I'm in Grade Six. My favourite subject is Maths."

TEXT

Speaker A: Hello, Sir. May I take yo\_\_\_\_\_ order, please?

Speaker B: Hello. What's your main di\_\_\_\_\_?

Speaker A: Well, today we have roasted king fish and fried ri\_\_\_\_\_.

Speaker B: Emm. I'd prefer roasted chic\_\_\_\_\_ and some salad.

Speaker A: And what would you like t\_\_\_\_\_ drink?

Speaker B: I'd like so\_\_\_\_\_ orange juice, please.

Speaker A: Orange juice. OK Sir. After the meal, would you like something f\_\_\_\_\_ dessert?

Speaker B: Yes, I'll have a cake with a cup o\_\_\_\_\_ coffee, please.

Speaker A: OK. Your meal wi\_\_\_\_\_ be ready in short ti\_\_\_\_\_.

GRM/VCB  
SCORE

10

**READING 1 (Items 1-4)**

**(4 marks)**

Match the four texts on the left with the texts in the box. Shade in the bubble  under the correct option.

1. Teenagers around the world usually have a similar interest which is hanging out with their friends.
2. Many people take painkillers when they feel stressed or have aches or pains in order to relax.
3. Writing is a very important skill that needs a lot of practice.
4. Money is very important and people collect and save it for many reasons.

<b>A.</b> One can get better in it by learning from own mistakes and a teacher's feedback is also important.
<b>B.</b> It has always been known that a book can be like a friend for those who love reading.
<b>C.</b> However, what they do outside may differ from one country to another.
<b>D.</b> It can sometimes be quite boring to do the same things repeatedly over time.
<b>E.</b> Some of those medicines could be harmful if they are not prescribed by a doctor.
<b>F.</b> Some spend it on entertainment, some give it for charity and others just use it for shopping purposes.

	A	B	C	D	E	F
1.	<input type="radio"/>	<input type="radio"/>	<input type="radio"/>	<input type="radio"/>	<input type="radio"/>	<input type="radio"/>
2.	<input type="radio"/>	<input type="radio"/>	<input type="radio"/>	<input type="radio"/>	<input type="radio"/>	<input type="radio"/>
3.	<input type="radio"/>	<input type="radio"/>	<input type="radio"/>	<input type="radio"/>	<input type="radio"/>	<input type="radio"/>
4.	<input type="radio"/>	<input type="radio"/>	<input type="radio"/>	<input type="radio"/>	<input type="radio"/>	<input type="radio"/>



**READING 2 (Items 5–10)****(6 marks)***Read the text. Then complete the task.*

Dear Said,

How are you? I hope you are well and enjoying good health. I am happy to write you this e-mail and I am sorry I didn't reply yesterday. It's because I was out with my family. You asked for information about The Great Wall Of China for your school project. In fact, I did a project about the same topic last semester and this semester my teacher asked me to write about Bahla Wall.

Here is the information you need. The Great Wall of China is an ancient wall in China. It is so large that the men who landed on the moon could see it. It is the largest wall in the world. It begins at Shanhaikun on the yellow sea and ends at Chaiyukan in Gobi Desert. It is almost three thousands kilometres long, 30 feet wide and 15 metres high. It is not only a wall, it has many thousands of towers. Most of the wall is made of stone. In some places, however, it is only made of dirt. The Chinese people started building the wall in 214 BC to keep out their enemies. It has 7,000 watch towers, block houses for soldiers and beacons to send smoke signals.

I hope this information can help you in your project. Have a good time and bye for now.

Best wishes.

Ahmed

**READING 2 (continued)**

For each item, write a short answer (not more than **FOUR WORDS**).

5. Why did not Ahmed reply to Said's e-mail soon?

---

6. When did Ahmed write about the Wall of China?

---

7. How long is it?

---

8. What is China Wall made of?

---

9. Why did the Chinese build the wall of China?

---

10. Where did the soldiers live?

---

READING  
SCORE

--

--

10
----





WRITING 2

(5 marks)

Write a story of at least **75 words** based on the following pictures.

You can use the words in the box to help you.

You can also put in more details to make your story lively and interesting.

old houses	photos	pot	heavy
coins	thank	gift	display

①



②

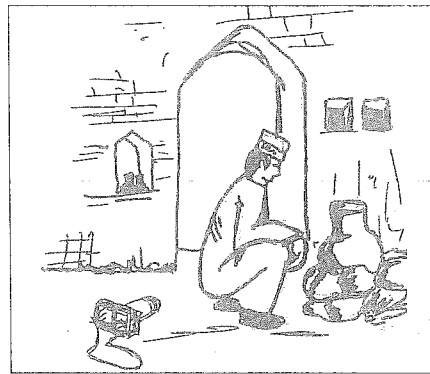

③



④

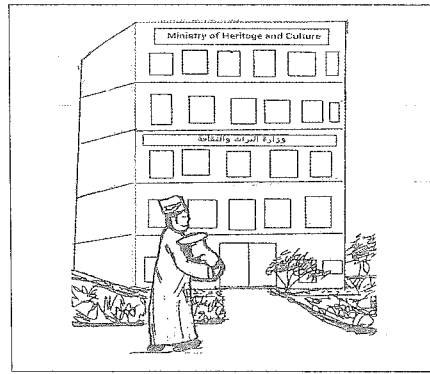

⑤



⑥

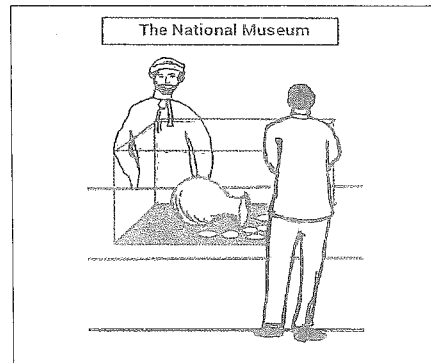



GRM/ VCB 2 (2.5 mks)	GRM/ VCB 3 (5 mks)	
6. <u>is</u> 7. <u>but</u> 8. <u>than</u> 9. <u>who</u> 10. <u>had</u>	11. <u>went</u> 12. <u>your</u> 13. <u>dish</u> 14. <u>rice</u> 15. <u>chicken</u>	16. <u>to</u> 17. <u>some</u> 18. <u>for</u> 19. <u>of</u> 20. <u>time</u>
<i>Notes: Half-a-mark each. Spelling <u>must be correct</u>.</i>	<i>Notes: Half-a-mark each. Spelling <u>must be correct</u>, including grammatical endings.</i>	

READING 1 (4 mks)							READING 2 (6 mks)	
	A	B	C	D	E	F		
1.	<input type="radio"/>	<input type="radio"/>	<input checked="" type="radio"/>	<input type="radio"/>	<input type="radio"/>	<input type="radio"/>	5.	Was out with family
2.	<input type="radio"/>	<input type="radio"/>	<input type="radio"/>	<input type="radio"/>	<input checked="" type="radio"/>	<input type="radio"/>	6.	Last semester
3.	<input checked="" type="radio"/>	<input type="radio"/>	<input type="radio"/>	<input type="radio"/>	<input type="radio"/>	<input type="radio"/>	7.	3000 kilometres/km
4.	<input type="radio"/>	<input type="radio"/>	<input type="radio"/>	<input type="radio"/>	<input type="radio"/>	<input checked="" type="radio"/>	8.	Stone and dirt
							9.	Keep out their enemies
							10.	Block houses
<i>Notes: One mark each. Responses must be indicated <u>clearly</u>.</i>							<i>Notes: One mark each. Complete accuracy in grammar and spelling is not required, but answers must be <u>clearly</u> and <u>convincingly</u> correct.</i>	

*2015/16*

WRITING 1 (5 mks)	
5	<ul style="list-style-type: none"> <li>– Discusses the topic in a lively, interesting way, making effective use of supporting arguments.</li> <li>– The points made by the writer are logically organised and very clear.</li> <li>– Makes use of a fair range of structures and vocabulary, with a good level of accuracy.</li> </ul>
4	<ul style="list-style-type: none"> <li>– Discusses the topic reasonably well, but use of supporting arguments is not fully effective.</li> <li>– The points made by the writer are reasonably well organized and mostly clear.</li> <li>– Use of grammar and vocabulary is reasonably correct, though rather limited in range.</li> </ul>
3	<ul style="list-style-type: none"> <li>– Expresses opinions with some use of supporting arguments, but only in a limited way.</li> <li>– The writer makes an attempt to organise his/her points, but this is only partly effective.</li> <li>– There is a noticeable lack of accuracy in the use of grammar and vocabulary.</li> </ul>
2	<ul style="list-style-type: none"> <li>– Makes an attempt to discuss the topic, but the result is unconvincing and clearly inadequate.</li> <li>– Weak organization makes it difficult to follow the points being made by the writer.</li> <li>– Grammar and vocabulary contain frequent serious errors.</li> </ul>
1	<ul style="list-style-type: none"> <li>– A <u>very</u> feeble attempt to discuss the topic. Very little relevant content.</li> <li>– The points made by the writer are confused and disjointed.</li> <li>– The language used is extremely limited and/or seriously distorted.</li> </ul>
0	<p><u>No attempt at the task:</u> EITHER Irrelevant (Completely unrelated to the topic) OR Hardly any writing at all, or not written in English OR Complete nonsense</p>

WRITING 2 (5 mks)	
5	<ul style="list-style-type: none"> <li>– Tells the story fully and clearly, in a lively, interesting way, providing appropriate details.</li> <li>– The text is coherent and easy to read. Not many language errors.</li> </ul>
4	<ul style="list-style-type: none"> <li>– Tells the story clearly enough, but writing lacks interest for the reader.</li> <li>– There are several noticeable language errors and the text sometimes lacks coherence.</li> </ul>
3	<ul style="list-style-type: none"> <li>– Manages to convey the main outline of the story, but only in a limited way.</li> <li>– Language used is limited in range and/or contains quite frequent errors.</li> </ul>
2	<ul style="list-style-type: none"> <li>– An attempt is made to tell the story, but important points are either missing or unclear.</li> <li>– Language used is very limited and/or contains many serious errors.</li> </ul>
1	<ul style="list-style-type: none"> <li>– A <u>very</u> feeble attempt to tell the story. Very little relevant content.</li> <li>– Language used is extremely limited and/or seriously distorted.</li> </ul>
0	<p><u>No attempt at the task:</u> EITHER Irrelevant (Completely unrelated to the pictures or to the task/ instructions) OR Hardly any writing at all, or not written in English OR Complete nonsense</p>

\* **NOTE:** In WRITING 2, test-writers actually have two different task-options to choose from (*Picture Story* or *Task Instructions*) when preparing the exam-paper. However, as both of these require student to produce a *narrative* text, the same Rating Scale can be used, whichever type of task they use.

\*\*\*\*\*

LISTENING 1 (5 mks)						
	A	B	C	D	E	F
1.	<input type="radio"/>	<input type="radio"/>	<input type="radio"/>	<input type="radio"/>	<input checked="" type="radio"/>	<input type="radio"/>
2.	<input type="radio"/>	<input checked="" type="radio"/>	<input type="radio"/>	<input type="radio"/>	<input type="radio"/>	<input type="radio"/>
3.	<input type="radio"/>	<input type="radio"/>	<input type="radio"/>	<input checked="" type="radio"/>	<input type="radio"/>	<input type="radio"/>
4.	<input type="radio"/>	<input type="radio"/>	<input checked="" type="radio"/>	<input type="radio"/>	<input type="radio"/>	<input type="radio"/>
5.	<input checked="" type="radio"/>	<input type="radio"/>	<input type="radio"/>	<input type="radio"/>	<input type="radio"/>	<input type="radio"/>

*Notes: One mark each. Responses must be indicated clearly.*

LISTENING 2 (5 mks)			
6.	<input type="radio"/> June	<input checked="" type="radio"/> July	<input type="radio"/> January
7.	<input type="radio"/> at Qatar Radio	<input checked="" type="radio"/> at the BBC	<input type="radio"/> in Paris
8.	<input checked="" type="radio"/> two	<input type="radio"/> three	<input type="radio"/> four
9.	<input type="radio"/> 1969	<input type="radio"/> 1967	<input checked="" type="radio"/> 1976
10.	<input type="radio"/> everybody	<input checked="" type="radio"/> Khartoum students	<input type="radio"/> international students only

*Notes: One mark each. Responses must be indicated clearly.*

GRM/ VCB 1 (2.5 mks)			
1.	<input checked="" type="radio"/> dangers	<input type="radio"/> achievements	<input type="radio"/> features
2.	<input type="radio"/> diseases	<input type="radio"/> adventures	<input checked="" type="radio"/> famines
3.	<input type="radio"/> clothes	<input type="radio"/> exams	<input checked="" type="radio"/> medicines
4.	<input checked="" type="radio"/> protect	<input type="radio"/> employ	<input type="radio"/> respect
5.	<input type="radio"/> generous	<input type="radio"/> careless	<input checked="" type="radio"/> careful

*Notes: Half-a-mark each. Responses must be indicated clearly.*



### Listening 1

You are going to hear five short texts about Sport. Match the pictures with the texts. For each text, shade in the bubble  under the correct option.

1. This sport can be played by people of different ages. In addition to the physical exercise it provides, many people use it for transportation.
2. This sport is also known as ping pong. It can be played by two or four players who hit a lightweight ball across the playing medium. It needs a lot of energy and concentration.
3. This is a team sport in which two teams of six players are separated by a net. Each team tries to score points by grounding the ball on the other team's court.
4. This sport is played by two teams of five players on a rectangular court. It is very popular in the USA and usually played by very tall people.
5. This sport is played in teams. It is the most popular sport in the world. It is played by a lot of people around the world. It needs a lot of strength and energy.

### Listening 2

You are going to hear a text about **Tayib Salih**, a famous Arab writer. For each item, shade in the bubble  next to the correct option.

Tayib Salih is a famous Sudanese writer. He was born on 12<sup>th</sup> July 1929 in northern province of Sudan. He spent most of his life outside of his land of birth. When he was a child, he went to a Quranic school. He did his secondary school education at Gordon College in Khartoum. He went to the University of Khartoum and then worked as a teacher. He occupied several jobs, such as the Head of drama at the BBC Arabic Service, the DG of Information in Qatar and with UNESCO in Paris. For about eleven years, he wrote a weekly column for a London-based Arabic magazine, called Al-Majalla.

Tayib Salih's writings focus on people and their complex relationships. His most famous novels are The Wedding of Zain and Season of Migration to the North. The Wedding of Zain, which was published in 1969, was made into an Arabic film and won an award at the Cannes Film Festival in 1976.

Tayib Salih died on 18th February 2009 at the age of 80. After his death, a yearly award was started in Khartoum. This award is not open to the general public, but only to the students of Khartoum International Community School.